

MARINE PANEL LAUTEX UPC-200

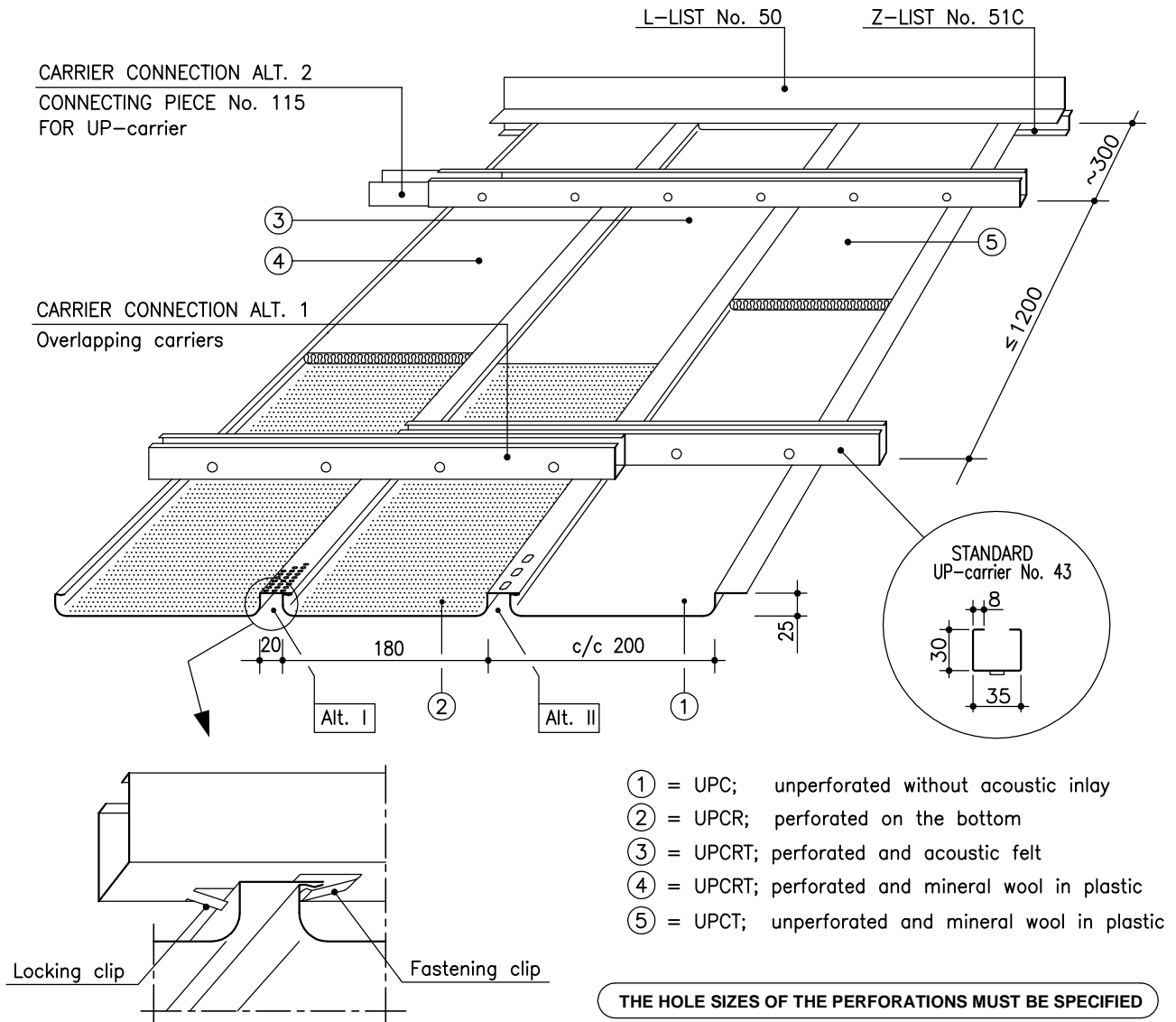

UPC-200 PANELS / CLASSIFICATION "C"

| | |
|-------------------------|---|
| Material | 0.7 Al |
| Width | 200 mm |
| Height | 25 mm |
| Length | max 6500 mm |
| Perforation | ∅ 2.0 or 3.5 mm, other alternatives see "Perforations" |
| Inlay | mineral wool in plastic or acoustic felt |
| Finish | stove enamelled (or anodized) according to LTX-colour card or any other well-known colour charts |
| Ventilation | alt I ∅ 3.5 mm, c/c 6.25 mm = 46 cm ² /m alt II ∅ 5x7 mm, c/c 13 mm = 23 cm ² /m |
| Protective film | the surface is provided with a protective film if required |
| Service hatch | see page 2 |
| Loudspeaker panel | see page 2 |
| Downlight unit | see page 2 |
| Suspension | see "Suspension systems for panels" |
| Edge lists | see "Lists for panels" |
| Other special solutions | please contact our technical information department |

Latest information: www.lautex.com

All products are subject to modifications without prior notice 2011

MARINE PANEL LAUTEX UPC-200 INSTALLATION DETAILS AND ACCESSORIES

SOLUTION OF PANEL CONNECTION

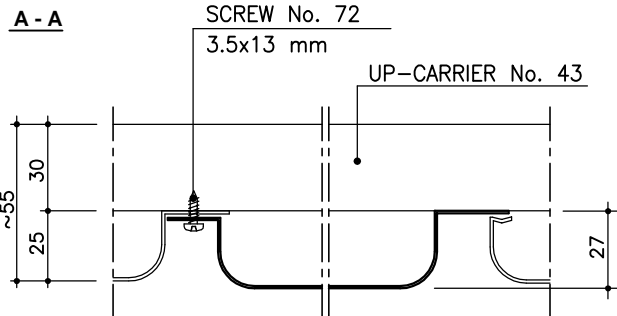
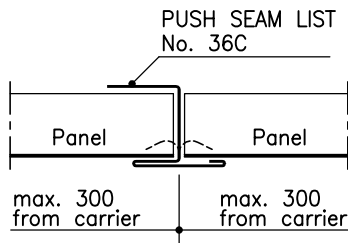

LOUDSPEAKER OR DOWNLIGHT PANEL

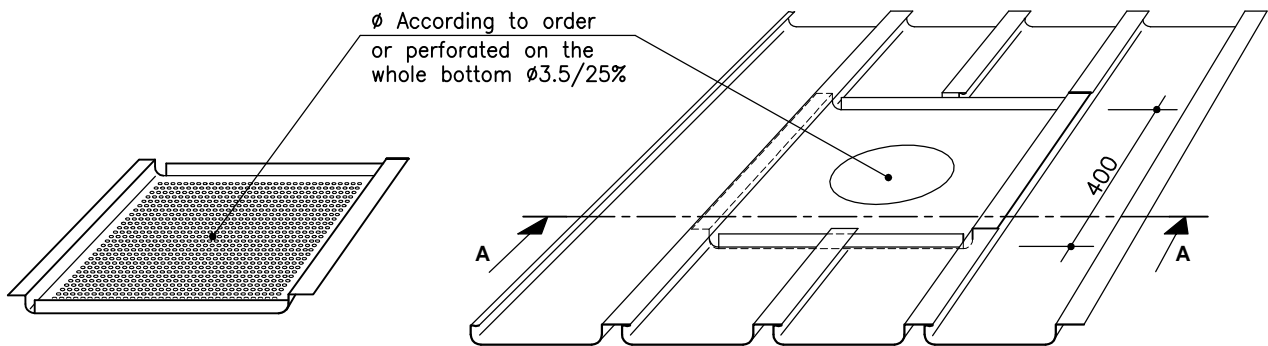

SERVICE HATCH

Length and width =
Opening in the ceiling
Standard sizes: 400 x 400
600 x 600

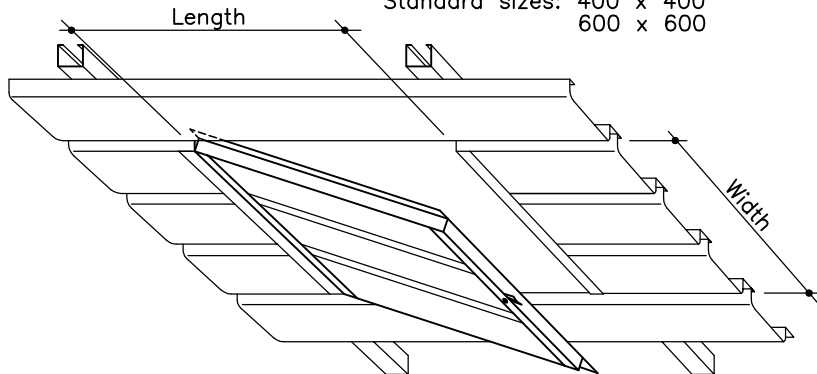

CONNECTION TO WALL

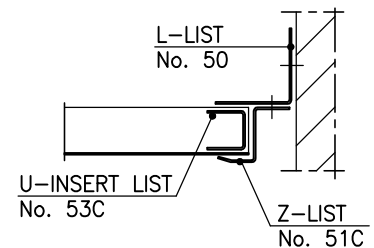

THEORETICAL NEED OF SUSPENSION STRUCTURES

| Product | Need of material |
|------------------------|----------------------------|
| Carrier No. 43 | 1.2 - 1.6 m/m ² |
| Carrier lock | 1 pcs / carrier meter |
| L-list No. 50 | 0.8 - 1.4 m/m ² |
| Z-list No. 51C | 0.8 - 1.4 m/m ² |
| U-insert list No. 53 C | 0.8 - 1.4 m/m ² |

WEIGHT OF PANELS KG / M²

| | UPC-200 |
|----------|---------|
| Material | 0.7 Al |
| Weight | 2.41 |

WEIGHT OF OTHER CEILING MATERIALS

| Product | Weight of material |
|--------------------------------|------------------------|
| Mineral wool in plastic | 0.52 kg/m ² |
| Carrier No. 43 | 0.83 kg/m |
| Carrier lock | 0.08 kg/pcs |
| L-list No. 50 (1.0 Al) | 0.21 kg/m |
| Z-list No. 51C (1.0 Al) | 0.16 kg/m |
| U-insert list No. 53C (0.7 Al) | 0.12 kg/m |

Latest information: www.lautex.com

All products are subject to modifications without prior notice 2011