

## MARINE PANEL LAUTEX UP-300 AND -200 / 25

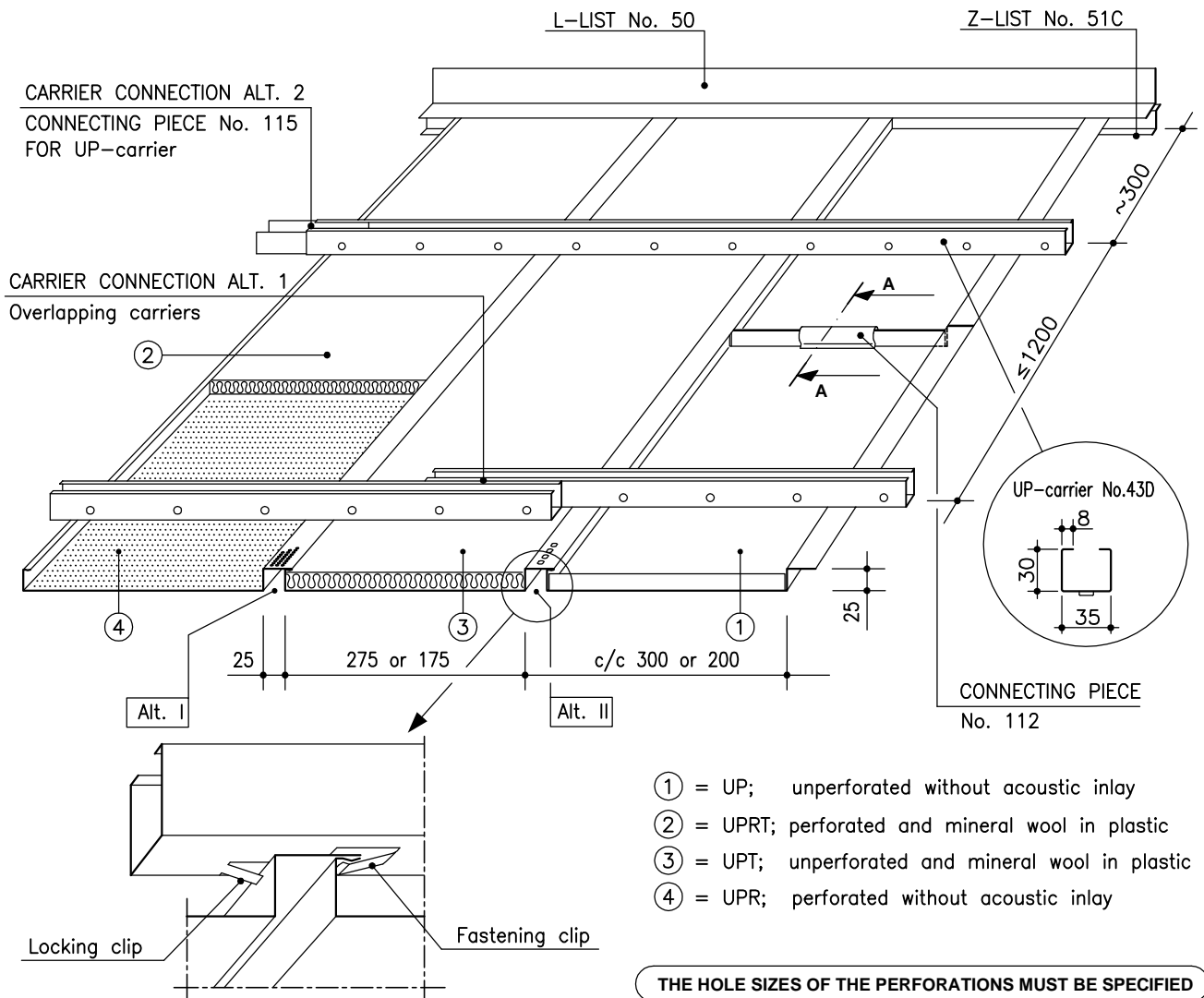

### UP-300 PANELS / CLASSIFICATION "C"

Material	0.7 Al 0.6 Steel
Width	300 mm or 200 mm
Height	25 mm
Length	max 4000 mm
Perforation	∅ 3.5 mm, other alternatives see "Perforations"
Inlay	mineral wool in plastic
Finish	stove enamelled (or anodized) according to LTX-colour card or any other well-known colour charts
Ventilation	alt I ∅ 3.5 mm, c/c 6.25 mm = 46 cm <sup>2</sup> /m alt II ∅ 5x7 mm, c/c 13 mm = 23 cm <sup>2</sup> /m
Protective film	the surface is provided with a protective film if required
End bendings	standard for straight cut ends
Service hatch	see page 2
Loudspeaker panel	see page 2
Downlight unit	see page 2
Suspension	see "Suspension systems for panels"
Edge lists	see "Lists for panels"
Other special solutions	please contact our technical information department

Latest information: [www.lautex.com](http://www.lautex.com)

All products are subject to modifications without prior notice 2011

## MARINE PANEL LAUTEX UP-300 AND -200 / 25 INSTALLATION DETAILS AND ACCESSORIES

### SOLUTIONS OF PANEL CONNECTION

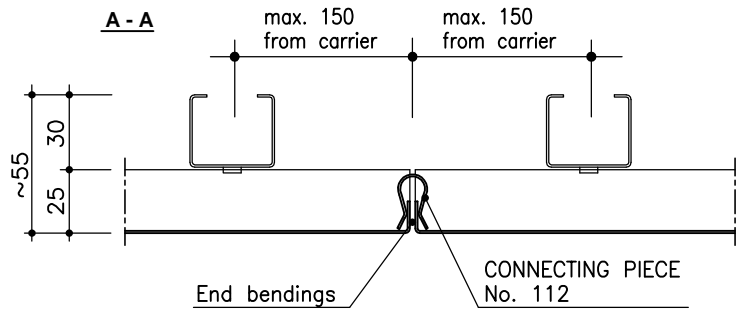
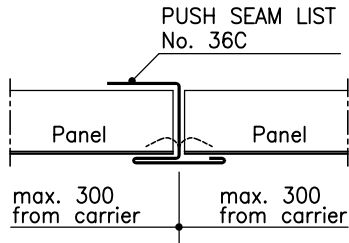

### LOUDSPEAKER OR DOWNLIGHT PANEL

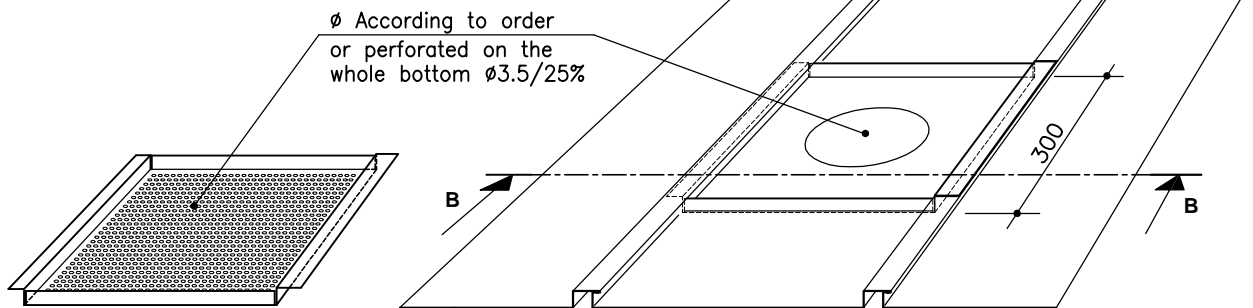

### SERVICE HATCH

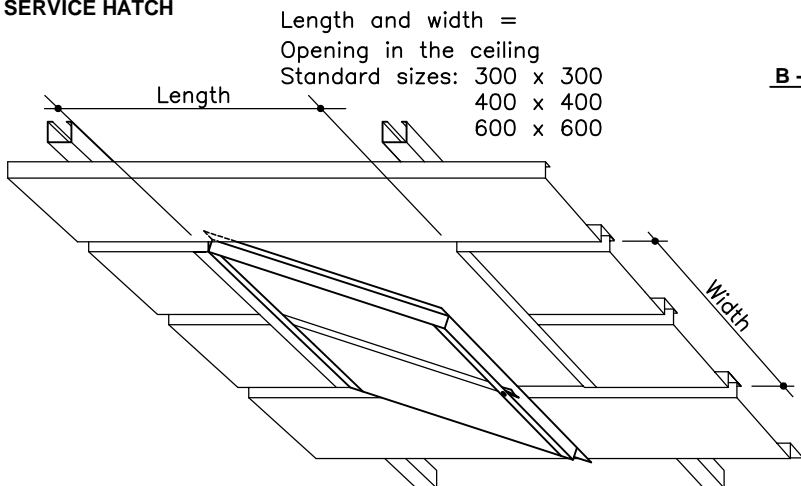

Length and width =  
Opening in the ceiling  
Standard sizes: 300 x 300  
400 x 400  
600 x 600

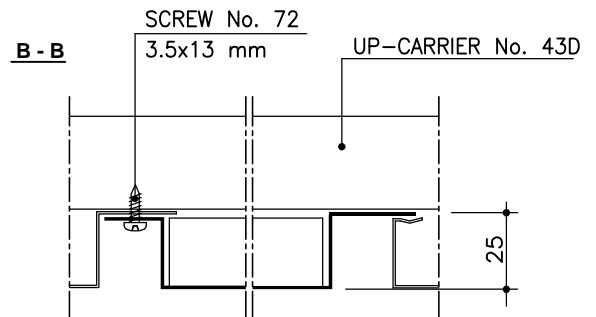

### THEORETICAL NEED OF SUSPENSION STRUCTURES

Product	Need of material
Carrier No. 43D	1.2 – 1.6 m/m <sup>2</sup>
Carrier lock	1 pcs / carrier meter
L-list No. 50	0.8 – 1.4 m/m <sup>2</sup>
Z-list No. 51C	0.8 – 1.4 m/m <sup>2</sup>
U-insert list No. 53C	0.8 – 1.4 m/m <sup>2</sup>

### WEIGHT OF PANELS KG / M<sup>2</sup>

	UP-300		UP-200/25	
Material	0.7 Al	0.6 Steel	0.7 Al	0.6 Steel
Weight	2.33	5.92	2.55	6.48

### WEIGHT OF OTHER CEILING MATERIALS

Product	Weight of material
Mineral wool in plastic	0.52 kg/m <sup>2</sup>
Carrier No. 43D	0.83 kg/m
Carrier lock	0.08 kg/pcs
L-list No. 50 (1.0 Al)	0.21 kg/m
Z-list No. 51C (1.0 Al)	0.16 kg/m
U-insert list No. 53C (0.7 Al)	0.12 kg/m

Latest information: [www.lautex.com](http://www.lautex.com)

All products are subject to modifications without prior notice 2011