

## MARINE PANEL LAUTEX UP-200 / 15

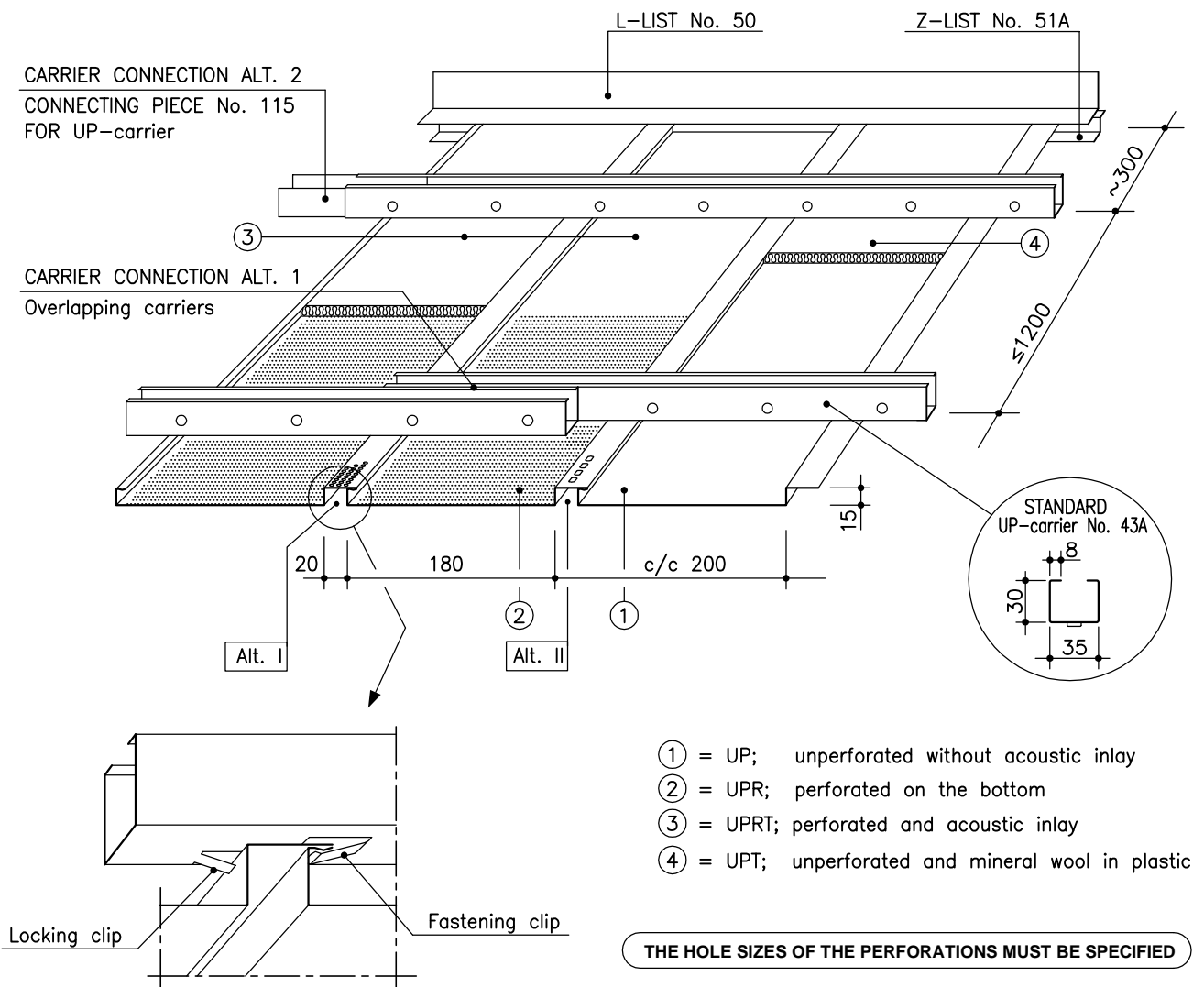

### UP-200 PANELS / CLASSIFICATION "C"

|                         |   |
|-------------------------|---|
| Material                | 0.7 Al      0.5 Steel   |
| Width                   | 200 mm  |
| Height                  | 15 mm   |
| Length                  | max 6500 mm   |
| Perforation             | Ø 2.0 mm, other alternatives see "Perforations"   |
| Inlay                   | mineral wool in plastic or acoustic felt  |
| Finish                  | stove enamelled (or anodized)<br>according to LTX-colour card or<br>any other well-known colour charts    |
| Ventilation             | alt I Ø 3.5 mm, c/c 6.25 mm = 46 cm <sup>2</sup> /m<br>alt II Ø 5x7 mm, c/c 13 mm = 23 cm <sup>2</sup> /m |
| Protective film         | the surface is provided with a protective film if required  |
| End bendings            | according to order  |
| Service hatch           | see page 2  |
| Loudspeaker panel       | see page 2  |
| Downlight unit          | see page 2  |
| Suspension              | see "Suspension systems for panels"   |
| Edge lists              | see "Lists for panels"  |
| Other special solutions | please contact our technical information department   |

Latest information: [www.lautex.com](http://www.lautex.com)

All products are subject to modifications without prior notice 2011

## MARINE PANEL LAUTEX UP-200 / 15 INSTALLATION DETAILS AND ACCESSORIES

### SOLUTIONS OF PANEL CONNECTION

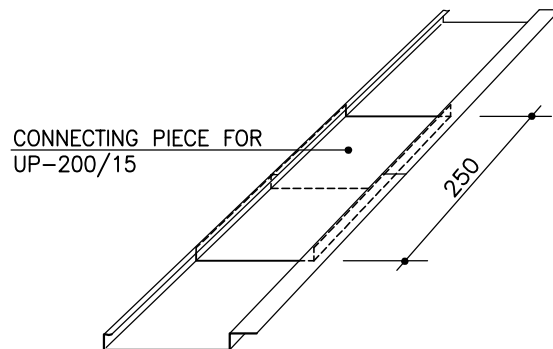
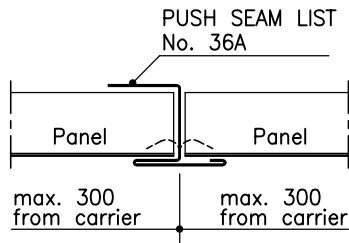

### LOUDSPEAKER OR DOWNLIGHT PANEL

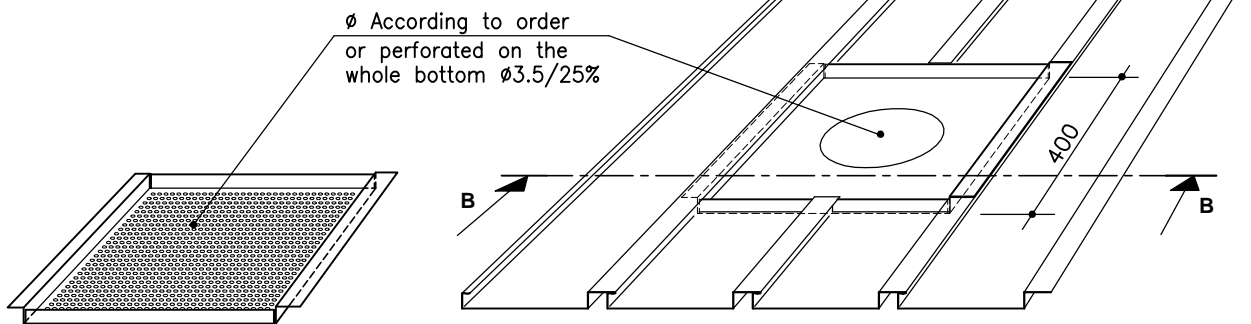

### SERVICE HATCH

Length and width =  
Opening in the ceiling  
Standard sizes: 400 x 400  
600 x 600

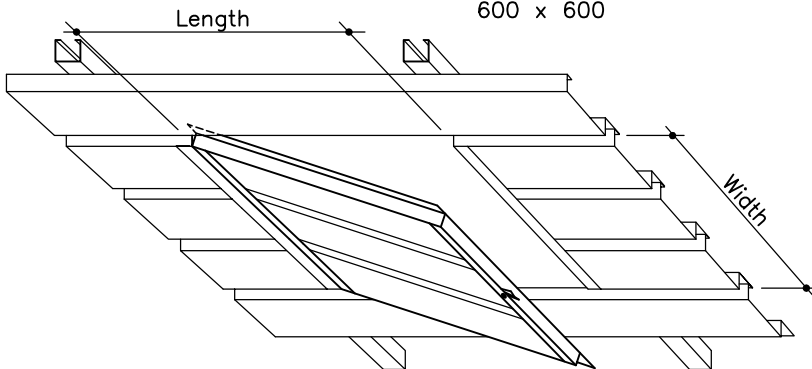

**B - B**

SCREW No. 72  
3.5x13 mm

UP-CARRIER No. 43

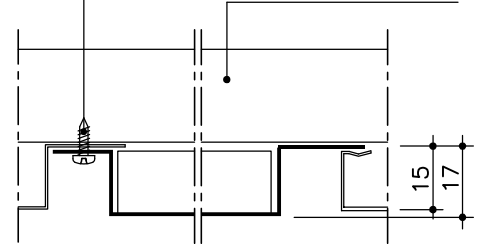

### THEORETICAL NEED OF SUSPENSION STRUCTURES

| Product         | Need of material           |
|-----------------|----------------------------|
| Carrier No. 43A | 1.2 - 1.6 m/m <sup>2</sup> |
| Carrier lock    | 1 pcs / carrier meter      |
| L-list No. 50   | 0.8 - 1.4 m/m <sup>2</sup> |
| Z-list No. 51A  | 0.8 - 1.4 m/m <sup>2</sup> |

### WEIGHT OF PANELS KG / M<sup>2</sup>

|          | UP-200/15 |           |
|----------|-----------|-----------|
| Material | 0.7 Al    | 0.5 Steel |
| Weight   | 2.27      | 4.80      |

### WEIGHT OF OTHER CEILING MATERIALS

| Product                 | Weight of material     |
|-------------------------|------------------------|
| Mineral wool in plastic | 0.52 kg/m <sup>2</sup> |
| Carrier No. 43A         | 0.83 kg/m              |
| Carrier lock            | 0.08 kg/pcs            |
| L-list No. 50 (1.0 Al)  | 0.21 kg/m              |
| Z-list No. 51A (1.0 Al) | 0.14 kg/m              |

Latest information: [www.lautex.com](http://www.lautex.com)

All products are subject to modifications without prior notice 2011