

MARINE PANEL LAUTEX UP-50

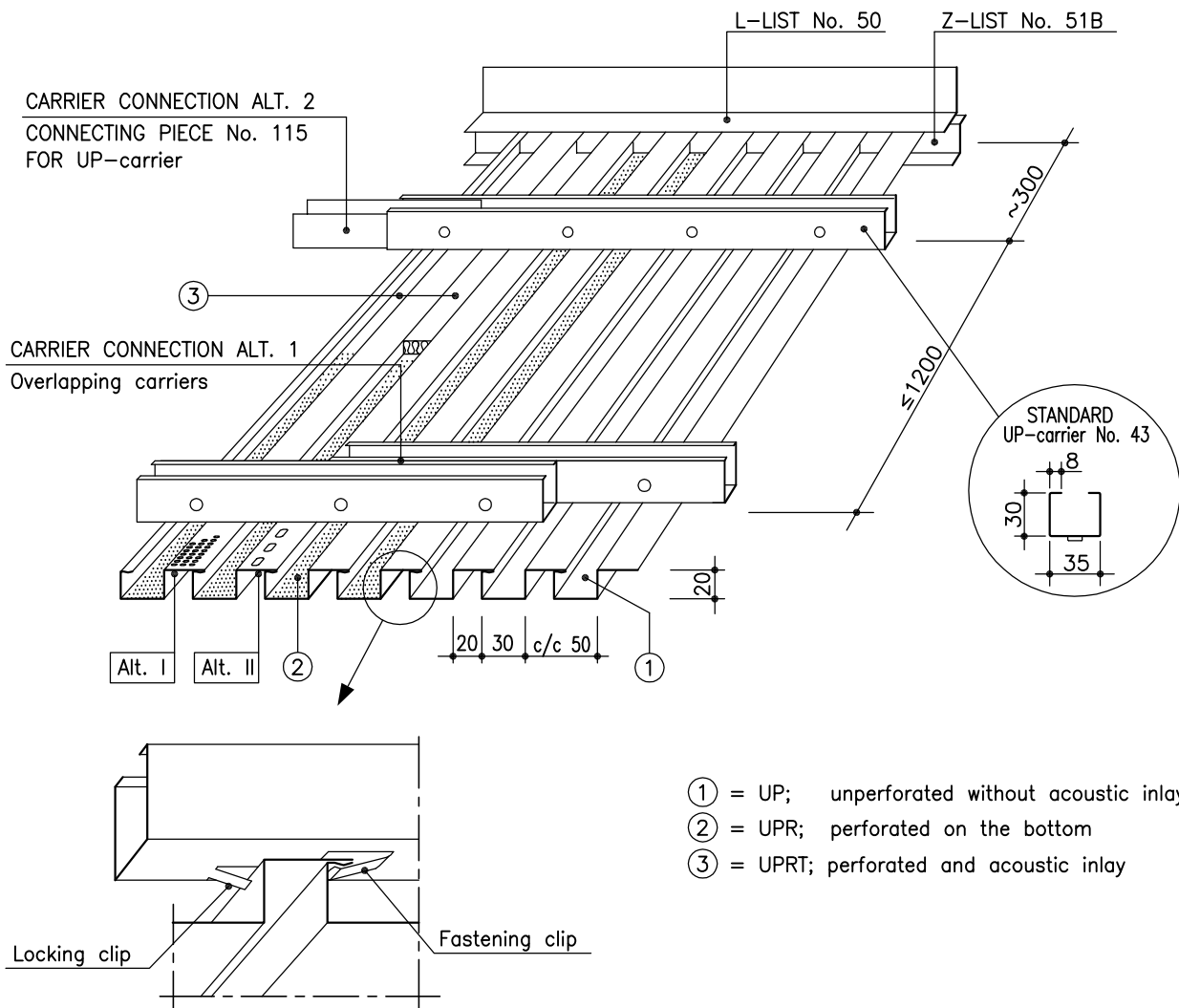

THE HOLE SIZES OF THE PERFORATIONS MUST BE SPECIFIED

UP-50 PANELS / CLASSIFICATION "C"

Material	0.5 Al 0.5 Fe
Width	50 mm
Height	20 mm
Length	max 6500 mm
Perforation	∅ 1.1 or 2.0 mm, other alternatives see "Perforations"
Inlay	mineral wool in plastic or acoustic felt
Finish	stove enamelled (or anodized) according to LTX-colour card or any other well-known colour charts
Ventilation	alt I ∅ 3.5 mm, c/c 6.25 mm = 46 cm ² /m alt II ∅ 5x7 mm, c/c 13 mm = 23 cm ² /m
Protective film	the surface is provided with a protective film if required
Service hatch	see page 2
Loudspeaker panel	see page 2
Downlight unit	see page 2
Suspension	see "Suspension systems for panels"
Edge lists	see "Lists for panels"
Other special solutions	please contact our technical information department

Latest information: www.lautex.com

All products are subject to modifications without prior notice 2006



OY LAUTEX AB

P.O. Box 58 FIN-03101 Nummela Finland
Tel +358 (0)9 224 8810 Fax +358 (0)9 222 5447
E-mail: sales@lautex.com www.lautex.com



MARINE PANEL LAUTEX UP-50

INSTALLATION DETAILS AND ACCESSORIES

SOLUTION OF PANEL CONNECTION

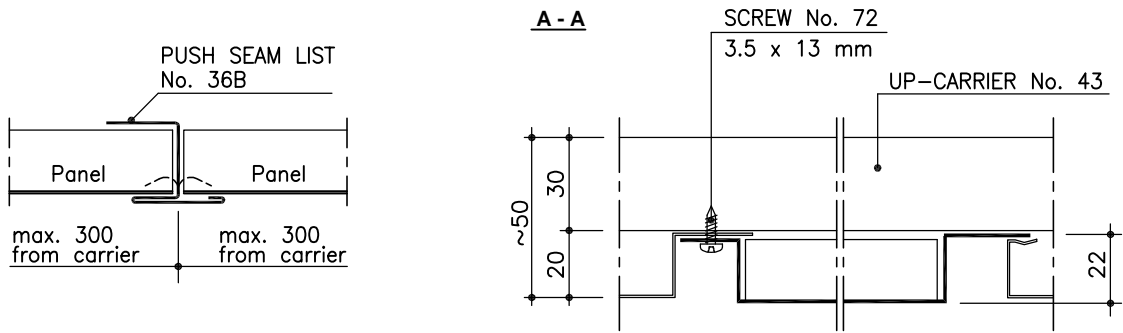

LOUDSPEAKER OR DOWNLIGHT PANEL

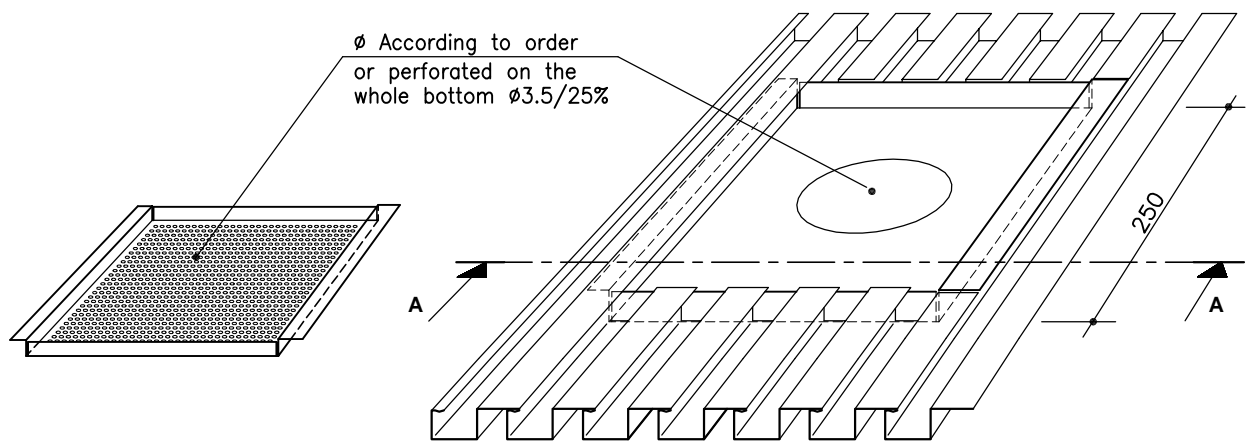

SERVICE HATCH

Length and width =
Opening in the ceiling

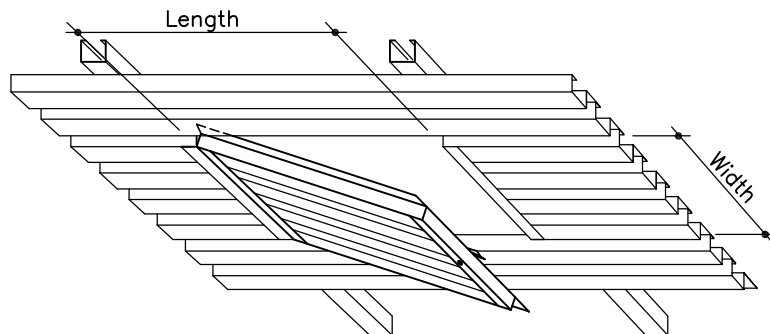

THEORETICAL NEED OF SUSPENSION STRUCTURES

Product	Need of material
Carrier No. 43	1.2 – 1.6 m/m ²
Carrier lock	1 pcs / carrier meter
L-list No. 50	0.8 – 1.4 m/m ²
Z-list No. 51B	0.8 – 1.4 m/m ²

WEIGHT OF PANELS KG / M²

	UP-50	
Material	0.5 Al	0.5 Fe
Weight	2.70	8.00

WEIGHT OF OTHER CEILING MATERIALS

Product	Weight of material
Mineral wool in plastic	0.52 kg/m ²
Carrier No. 43	0.83 kg/m
Carrier lock	0.08 kg/pcs
L-list No. 50 (1.0 Al)	0.21 kg/m
Z-list No. 51B (1.0 Al)	0.15 kg/m

Latest information: www.lautex.com

All products are subject to modifications without prior notice 2006



OY LAUTEX AB

P.O. Box 58 FIN-03101 Nummela Finland
Tel +358 (0)9 224 8810 Fax +358 (0)9 222 5447
E-mail: sales@lautex.com www.lautex.com

